

Electronics for IoT

DC Motor

Bernhard E. Boser

University of California, Berkeley

boser@eecs.berkeley.edu

Many Types of Motors

- DC
 - Brushed
 - Brushless
- Steppers
- Servos



- Characteristics
 - Voltage, AC, DC
 - Torque
 - RPM
 - Size, power, ...



DC Motor Applications

- Automotive
 - EV Drive Train
 - Turns wheels
 - Headlights
 - Windows
 - ...
- Aerospace
- Power Tools
- Robots
- Printers
- Fans
- AC

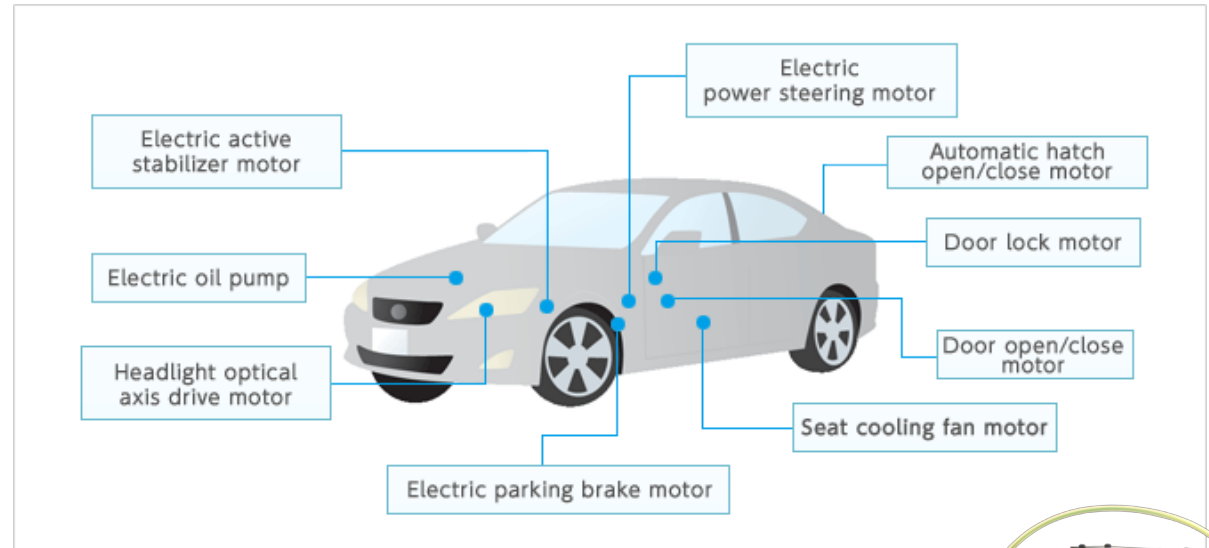

DC Motor Applications

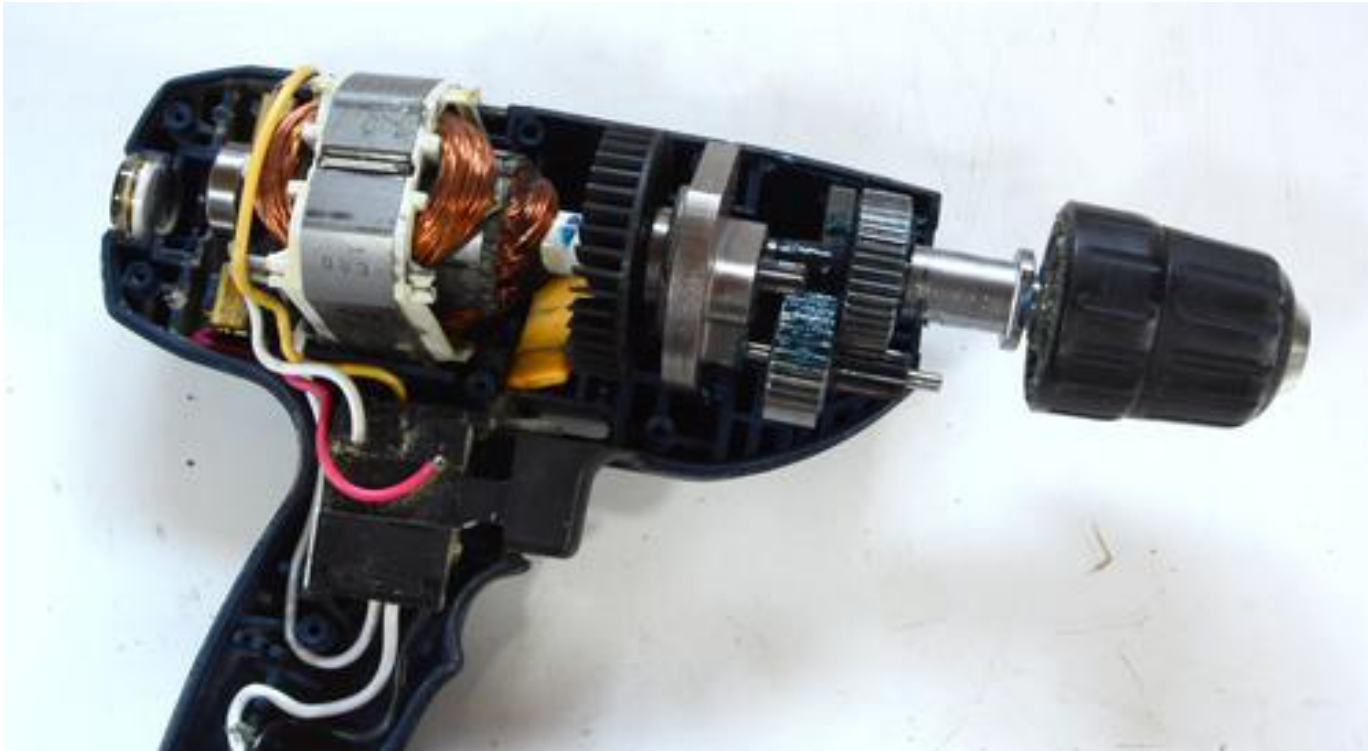

Torque

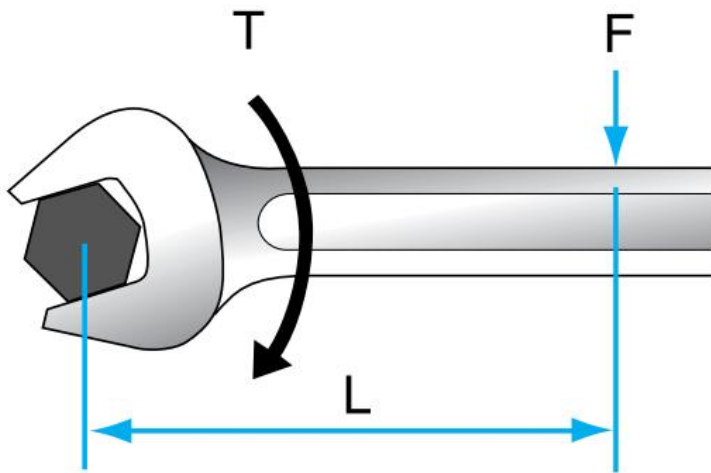

Torque $T = F$ (Force) \times L (Length)

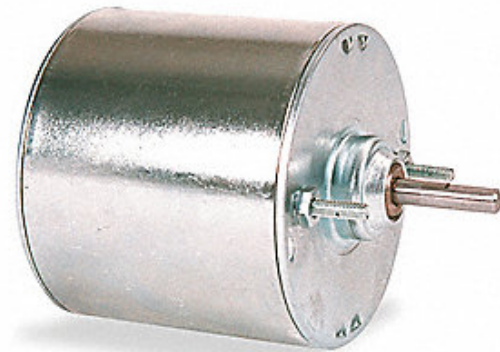

Lorentz Force

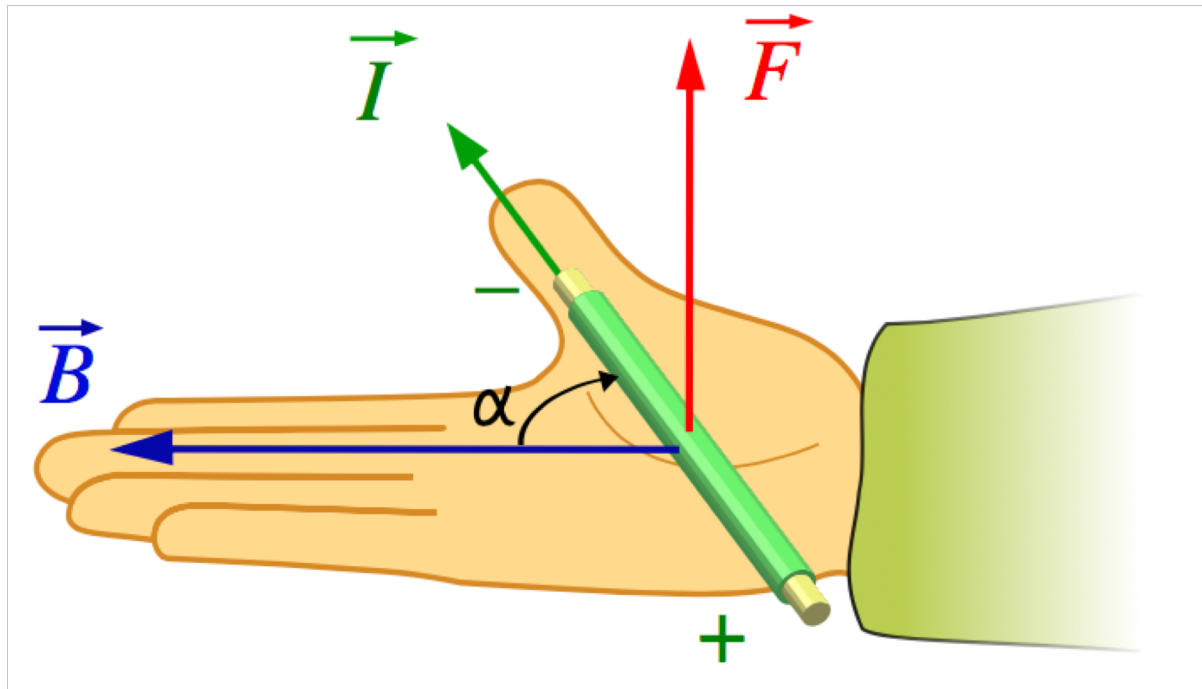

Electrical Motor Principle (1)

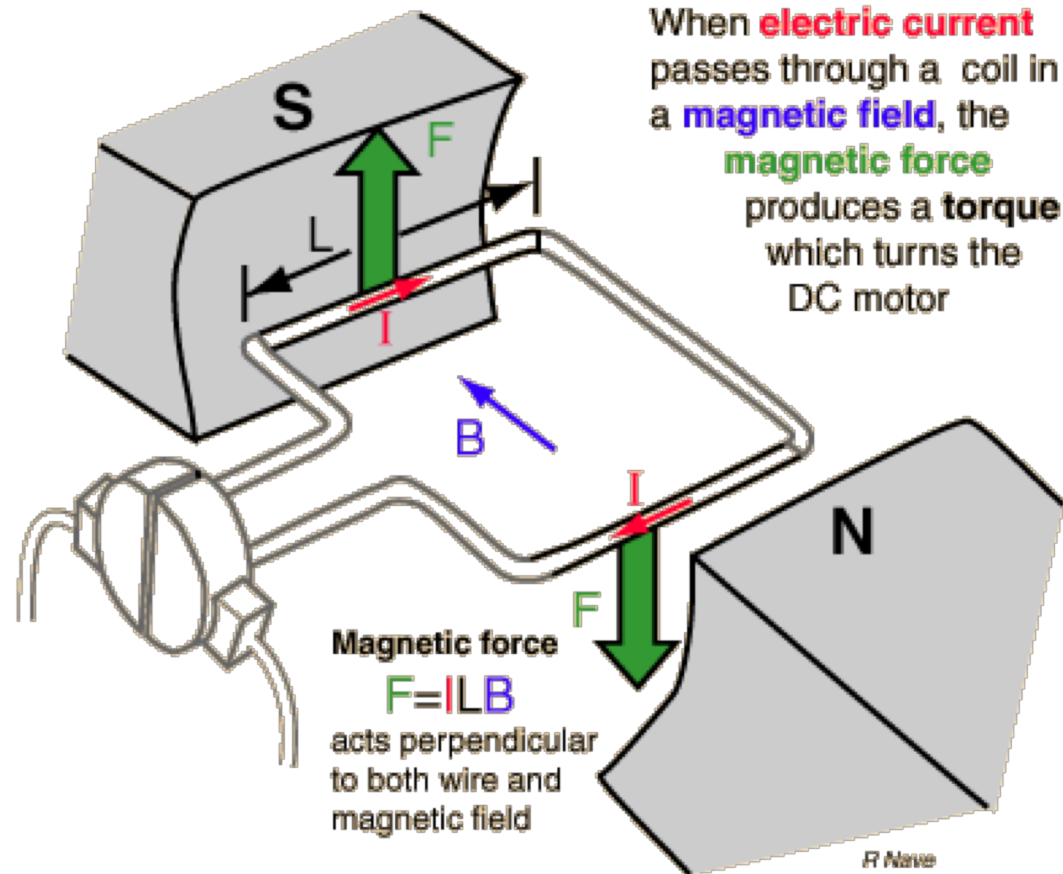

<https://www.pc-control.co.uk/dc-motors.htm>

Electrical Motor Principle (2)

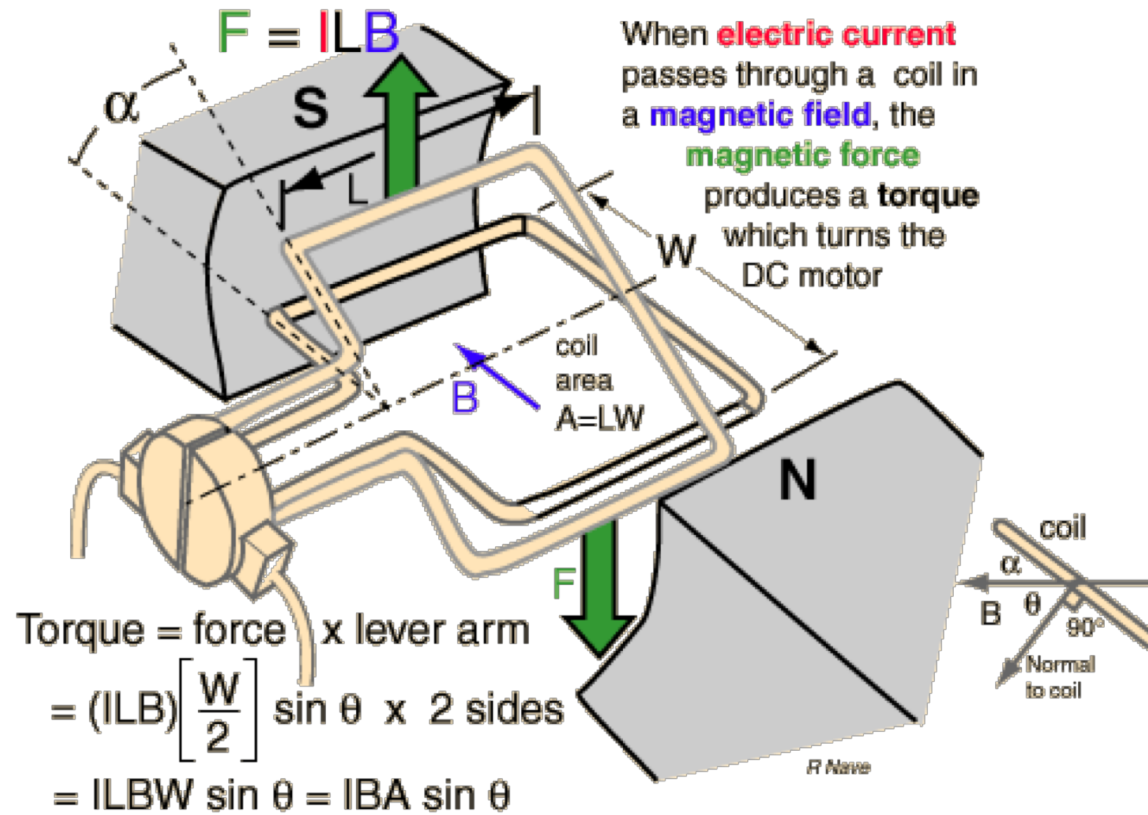

<https://www.pc-control.co.uk/dc-motors.htm>

Electrical Motor Principle (3)

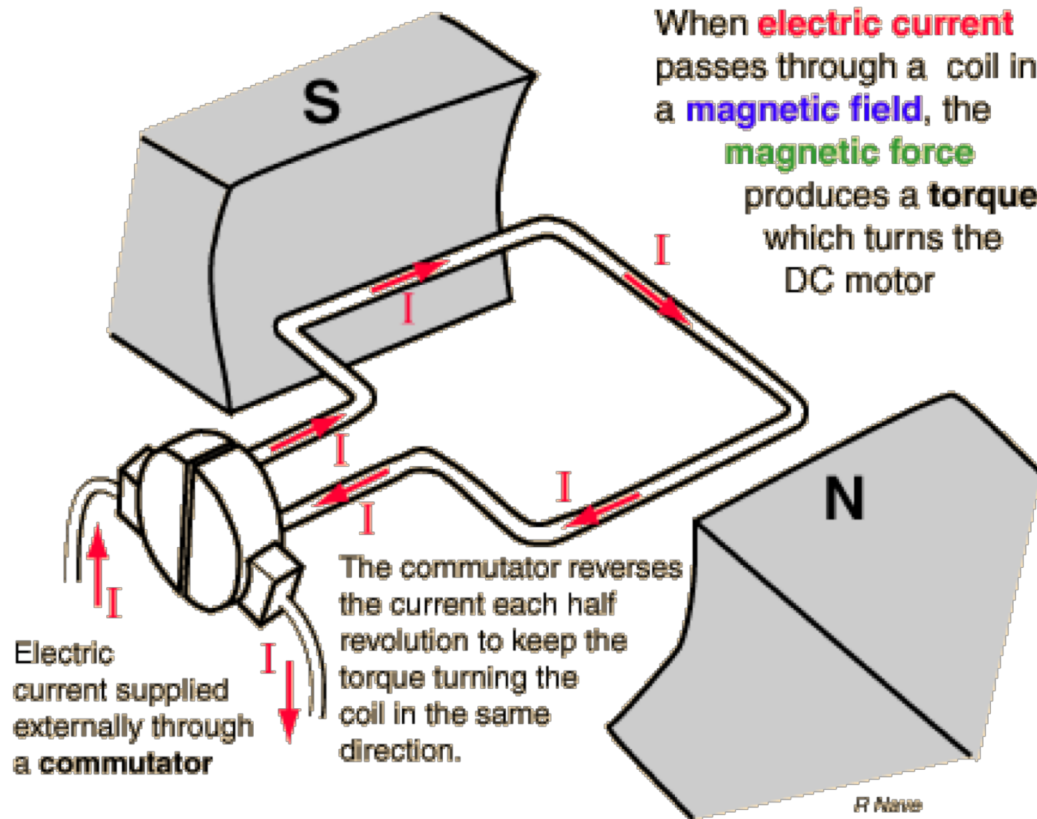

<https://www.pc-control.co.uk/dc-motors.htm>

Motor Nomenclature

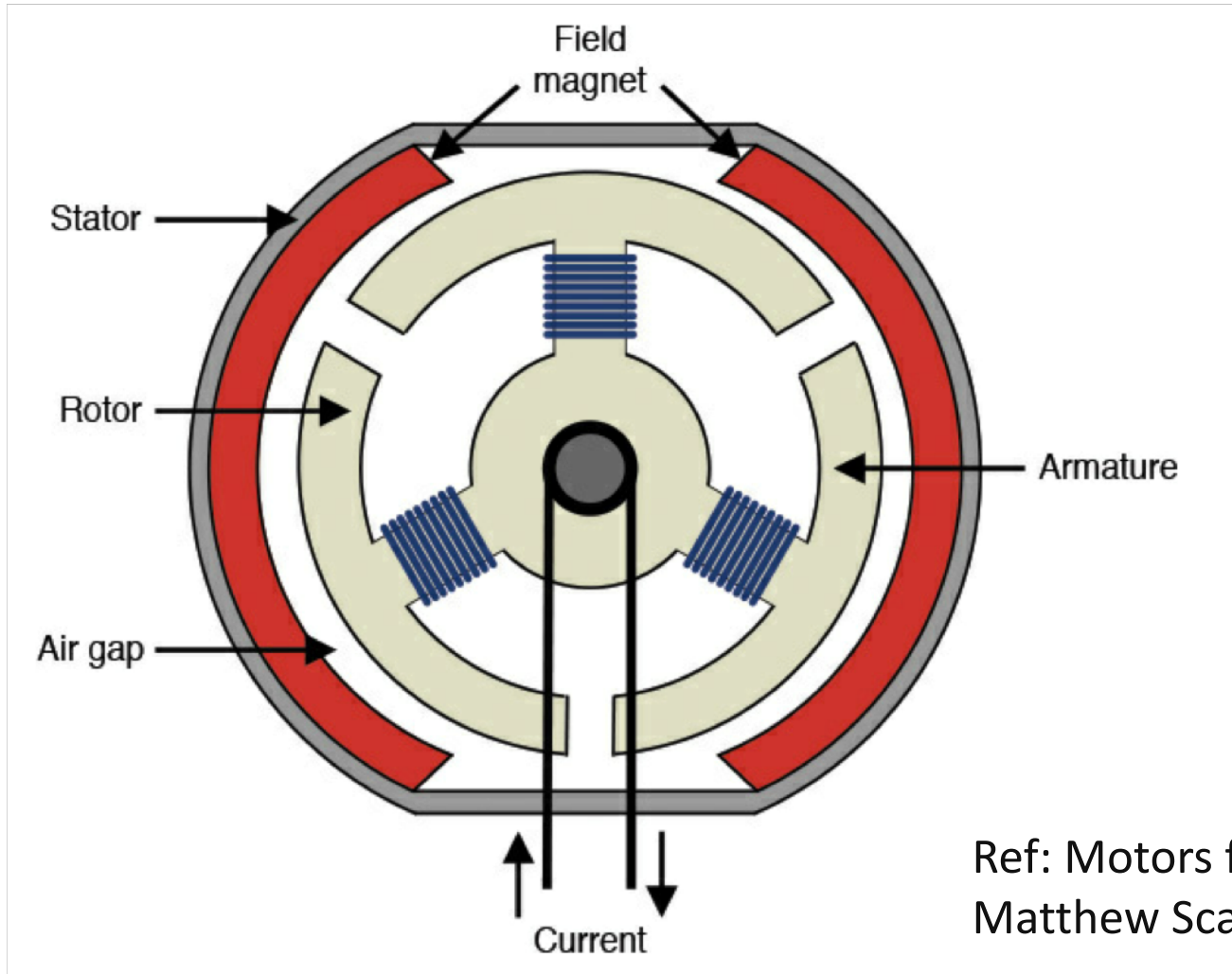

Ref: Motors for Makers,
Matthew Scarpino

Winding



Commutator

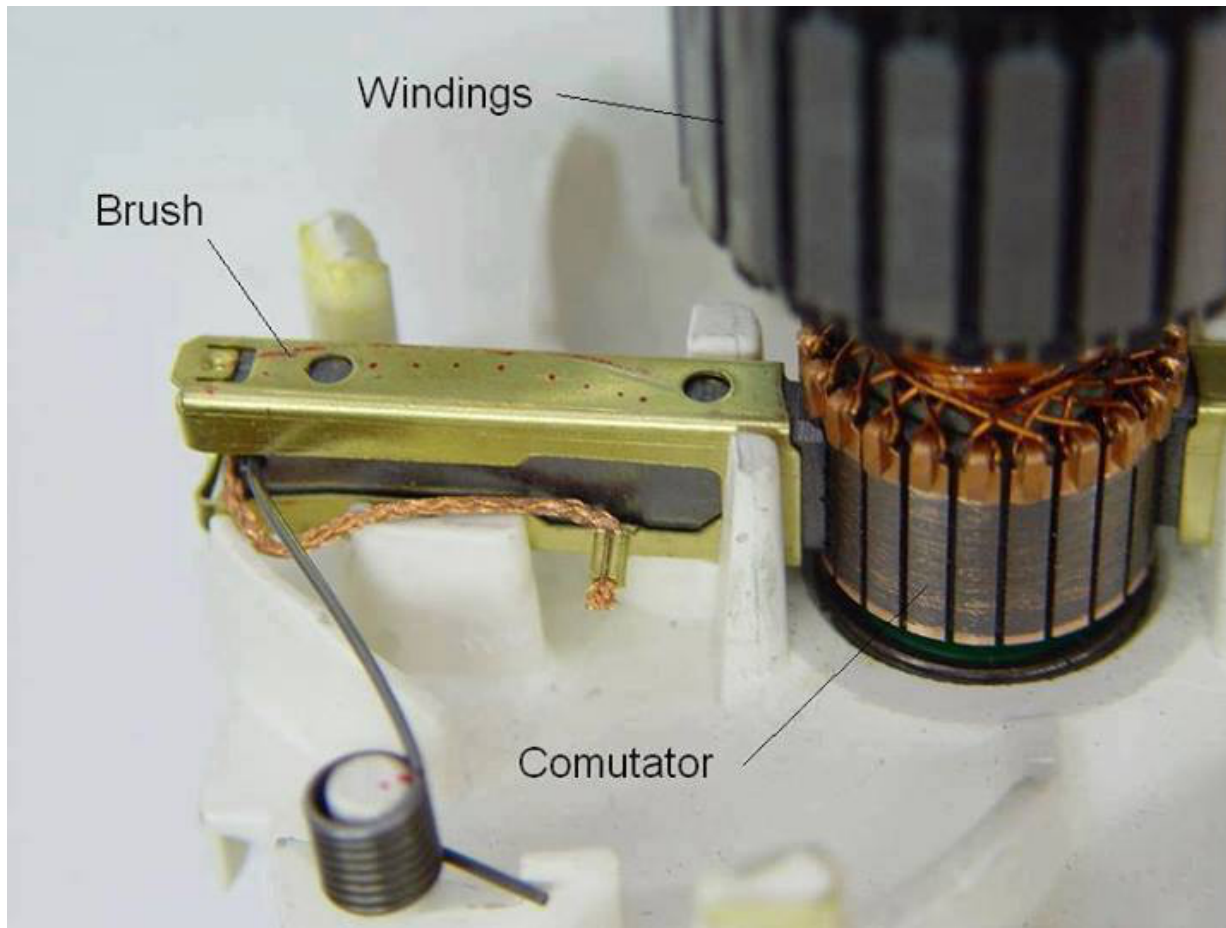

DC Motor

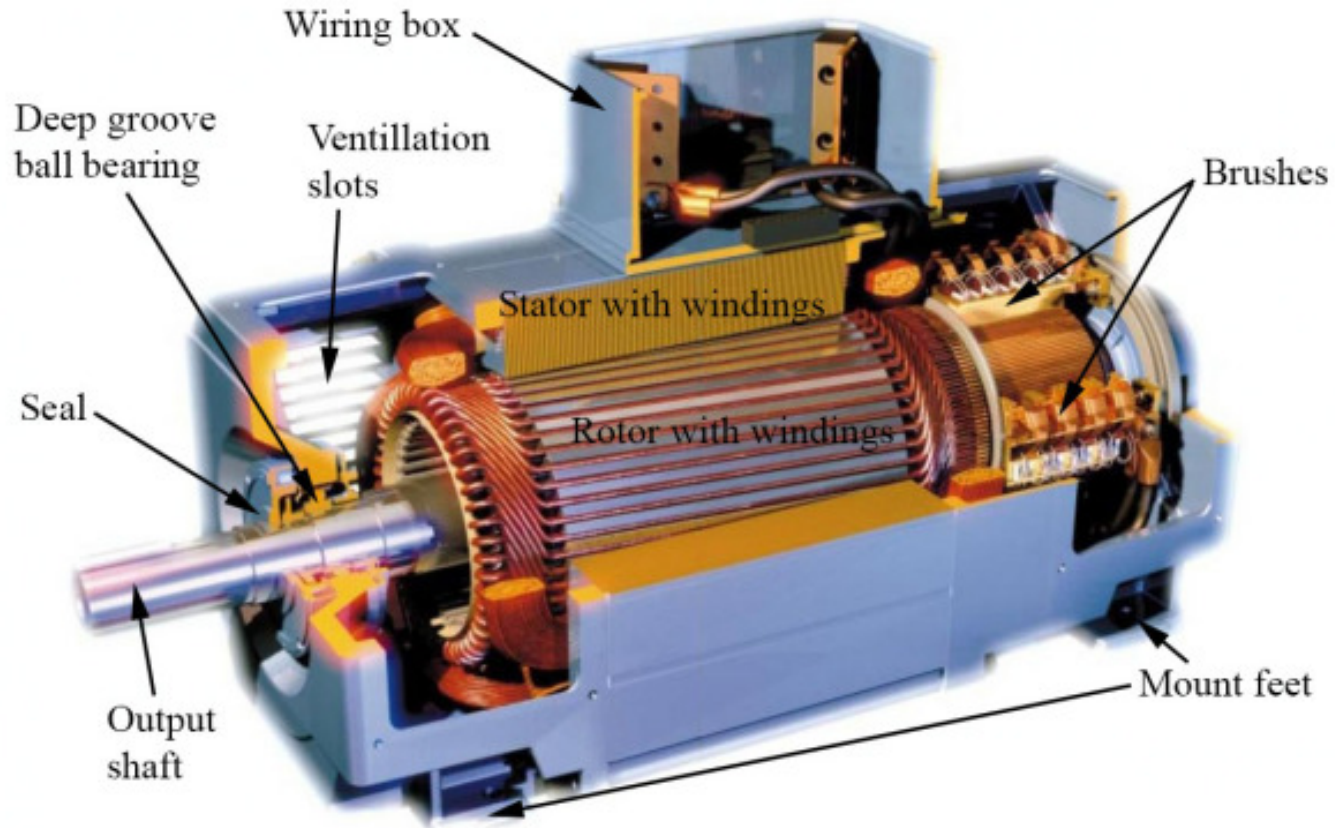

Torque τ vs Rotation Speed ω

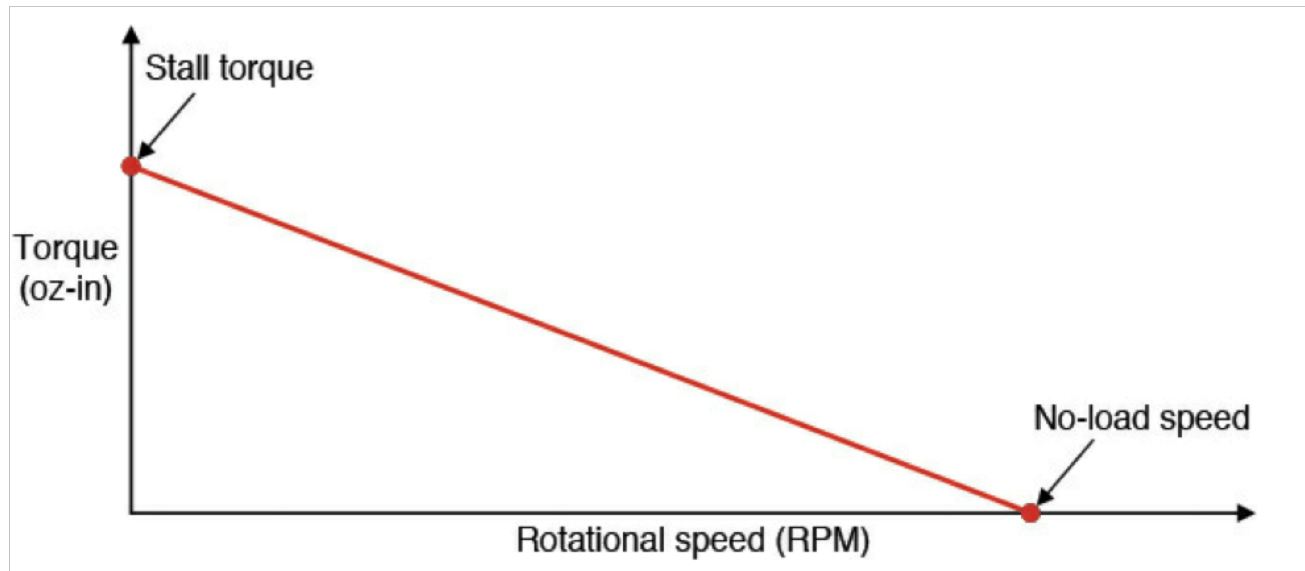

Power vs ω

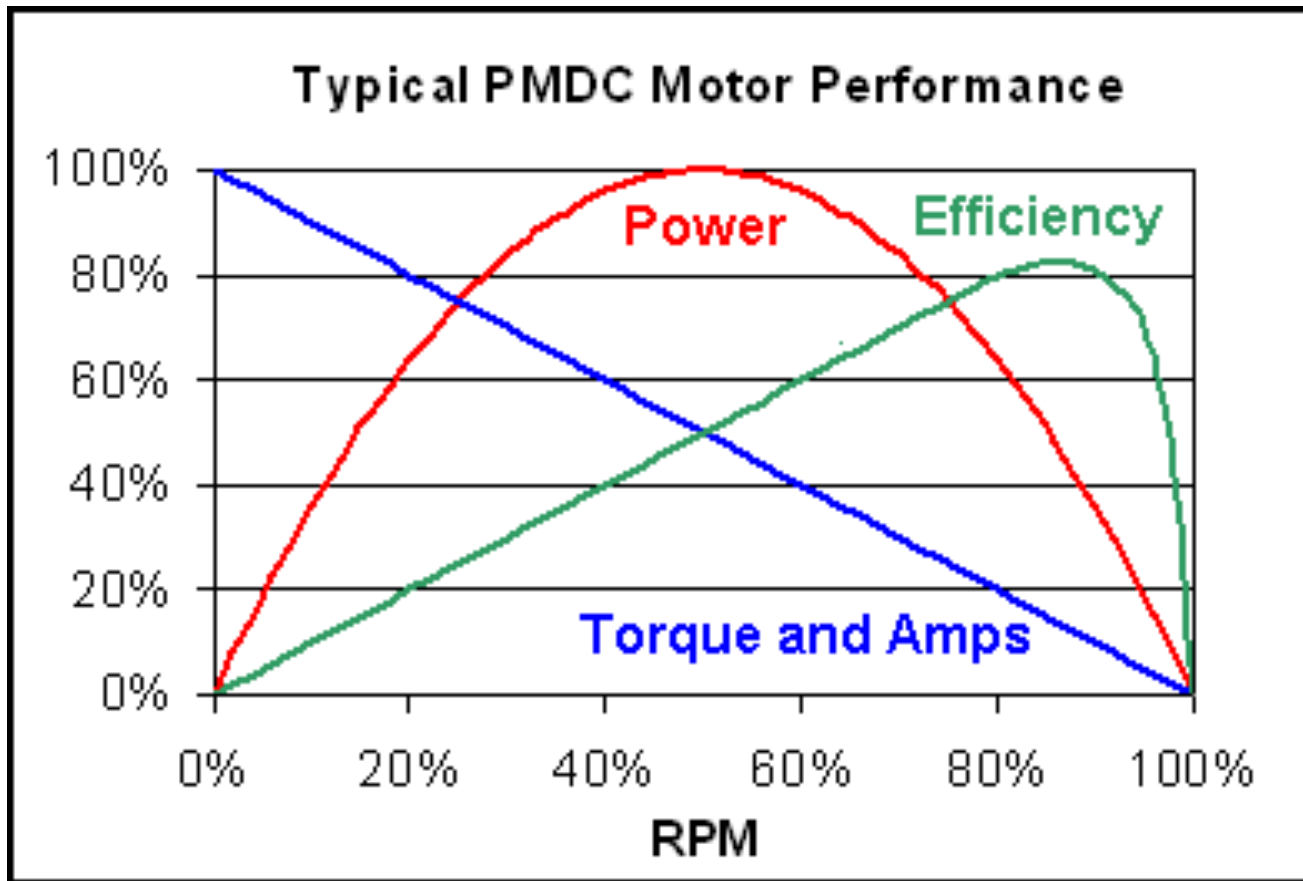

Speed Control

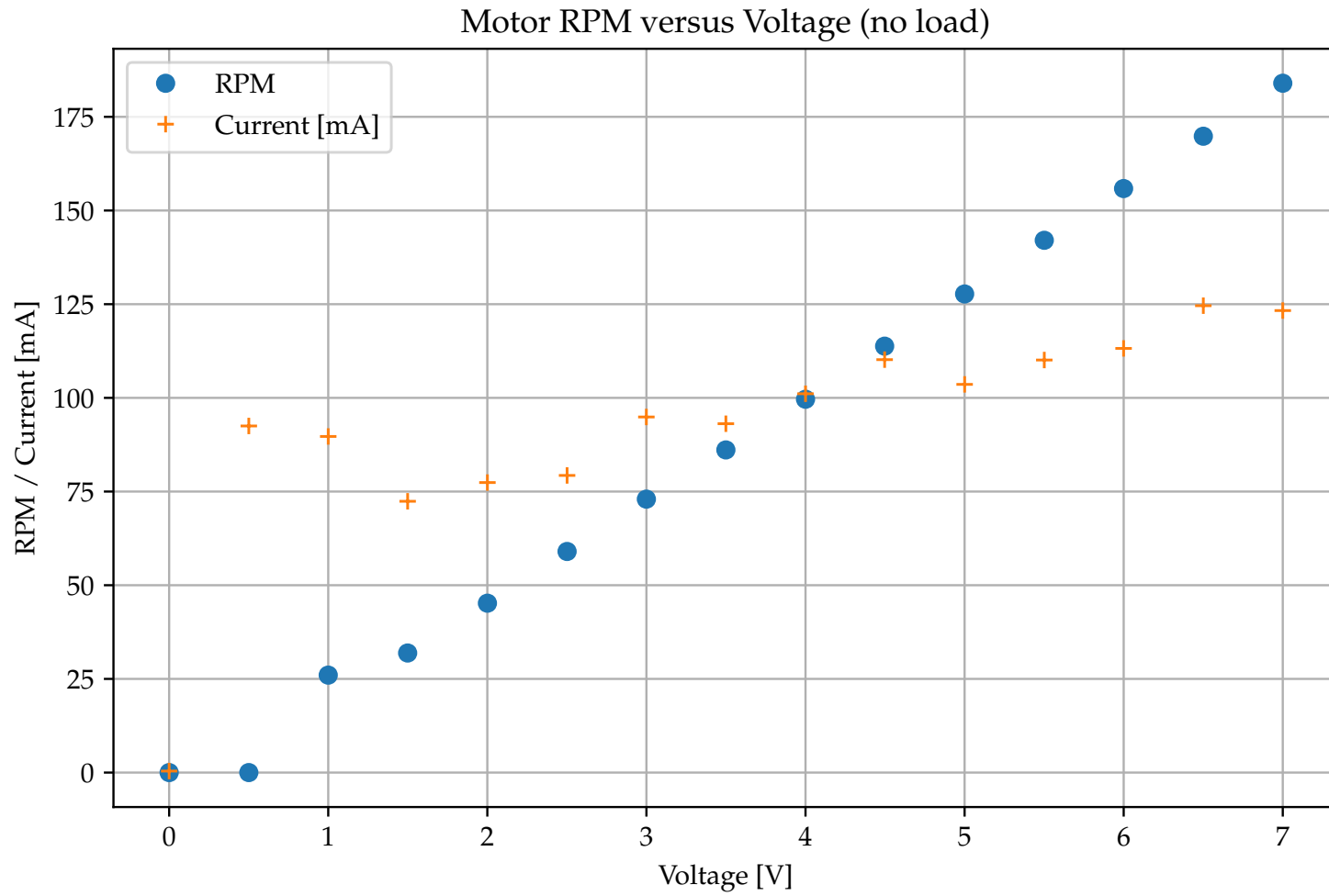

Gear Motors

