

1. Redo practice problem 5.9 in Alexander and Sadiku, 5h Edition. Replace the 8 kΩ resistor with 12 kΩ.
2. Redo practice problem 5.10 in Alexander and Sadiku, 5h Edition. Replace the 30 kΩ resistor with 40 kΩ.
3. Redo practice problem 6.3 in Alexander and Sadiku, 5h Edition for $t = 2$ ms.
4. Redo practice problem 6.10 in Alexander and Sadiku, 5h Edition. Replace the 6 Ω resistor with 5 Ω.
5. (5-7) Large resistor ratios are required if a big closed-loop gain $|v_o/v_i|$ is desired in an operational amplifier circuit. E.g. setting the gain of an inverting amplifier to -1000 requires resistors with values 10 kΩ and 10 MΩ or multiples thereof. Such large resistor values and ratios often exhibit unacceptably large variation, causing error in the closed-loop gain. In integrated circuits, large resistor values occupy a large area, increasing fabrication cost.

The circuit shown below requires resistor ratios that are much smaller than the closed-loop gain. Find the ratio R_2/R_1 such that $v_o/v_i = -693$. Use $R_1 = R_3 = 5$ kΩ and $R_2 = R_4$.

$R_2/R_1 =$

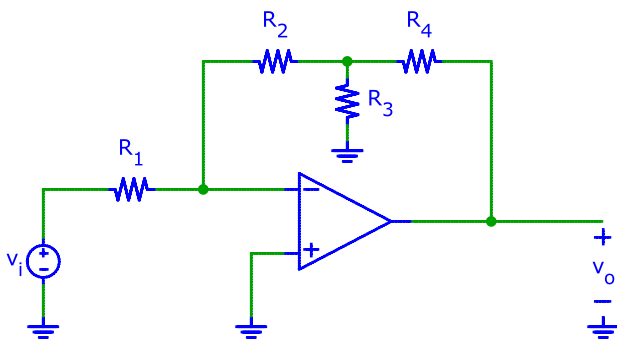

6. (5-10) The current i_x in the circuit below is independent of the value of R_x , i.e. the circuit realizes a current source i_x . Find i_x/v_i for $R = 2.7$ kΩ and $R_1 = 80$ kΩ.

Note: the unit of the result is [S] = [1/Ω] (Siemens).

$i_x/v_i =$

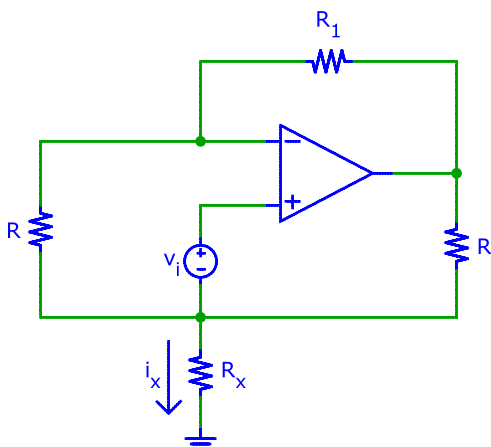

7. (5-11) The circuit below is part of an instrumentation amplifier. Calculate v_o for $R_1 = 8.8$ kΩ, $R_2 = 9.4$ kΩ, $R_3 = 3.8$ kΩ and $V_{i1} = 3.6$ V, $V_{i2} = 2.9$ V.

Suggestion: use circuit insight, not node voltage analysis.

$v_o =$

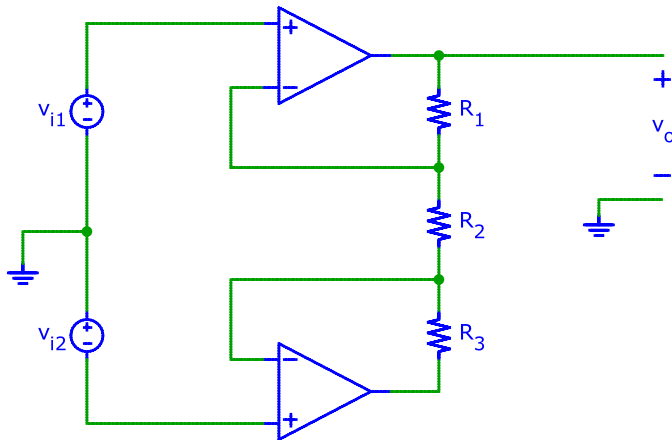

8. (5-13) The current into the input of an ideal operational amplifier is ideally zero. Many operational amplifiers come close to this ideal, with leakage currents in the pA or even fA range.¹ This corresponds to a very high input resistance (TΩ range) that is usually negligible.

High input resistance of the open-loop amplifier (i.e. without feedback resistors) does not always translate into the same characteristic for the closed-loop configuration. Specifically, non-inverting closed-loop configurations retain the high input resistance of the open-loop amplifier, but in inverting configurations the input resistance is determined by the feedback network and therefore much smaller.

The diagram below shows a test circuit. Calculate the input resistance $R_i = v_i/i_i$ for $R_1 = 8.2 \text{ k}\Omega$ and $R_2 = 93 \text{ k}\Omega$.

$R_i =$

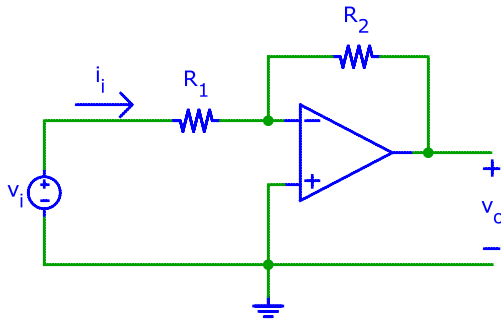

9. (D-41) A 663 mF capacitor is used to power a model airplane. Initially the capacitor is charged to $V_o = 7 \text{ V}$. Calculate the fraction r of the initial energy remaining on the capacitor after V_o has decreased to 75% of its initial value.

$r =$

10. (D-43) A 6.6 nF parallel plate capacitor with 83 μm gap is charged to 74 V. What is the electrostatic force F between the plates? Hint: force is the differential of energy with respect to displacement.

¹This depends on the type of amplifier. In particular, amplifiers with MOS or JFET inputs have very small input currents, while the input current of BJT amplifiers is much larger, often in the μA range. BJT amplifiers have other advantages, such as higher speed or output current capability and lower offset voltage. If low input resistance is critical, an operational amplifier with either MOS or JFET inputs is preferred.

$$|F| = \boxed{}$$

11. (D-45) Calculate the capacitance between nodes (a,b) for $C_1 = 1.5 \text{ pF}$, $C_2 = 3.9 \text{ pF}$, $C_3 = 4.8 \text{ pF}$, $C_4 = 6.8 \text{ pF}$.

$$C_{ab} = \boxed{}$$

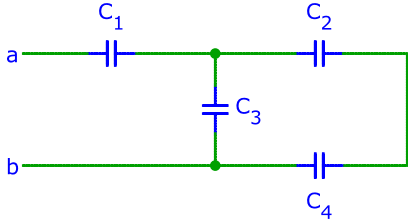

The remaining problems in this assignment are optional (practice for the midterm).

12. (5-12) Photodiodes are often used as light sensors (e.g. to measure ambient illumination or as receivers in fiberoptic communication systems). From a circuit perspective a photodiode behaves just like a current source i_D with output resistance R_D .

In practice, a voltage output is usually preferred. Without the amplifier circuit shown below, the change of the voltage across the photodiode is small and further depends on the value of R_D , which itself is a function of the signal. The amplifier solves both problems. Find the value of R_1 resulting in a transresistance v_o/i_D of $1.9 \text{ V}/\mu\text{A}$.

$$R_1 = \boxed{}$$

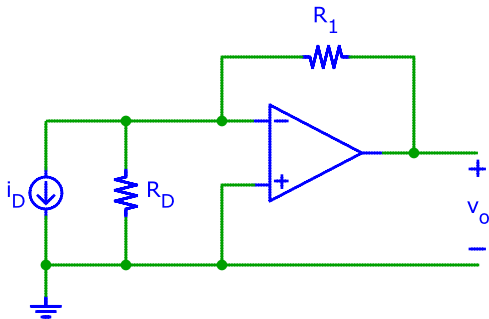

Such circuits have many applications, e.g. in electronic devices to measure ambient illumination and adjust the intensity of LCD back-lighting accordingly. Combined with an (LED) light source, this circuit can be used in an intruder alarm. Options for the class project.

13. (5-15) Sensor applications frequently call for amplification of a voltage difference. We have seen such a situation in the strain gage laboratory. Many sensors further have a high output resistance, requiring an amplifier with very large input resistance. The non-inverting amplifier has this characteristic, but the input resistance of the inverting amplifier is too small for many sensor applications and because of this cannot be used directly.

A solution is shown below that employs two non-inverting amplifiers to buffer the input signal, followed by an inverting stage that forms the difference. This configuration is usually referred to as "instrumentation amplifier". Since it has many uses, integrated circuits containing the complete structure are available from several manufacturers. The resistor R_{gain} is usually external and used to adjust the circuit gain. Calculate the gain $A_v = v_o/(v_{i1} - v_{i2})$ for $R_{\text{gain}} = 8 \text{ k}\Omega$, $R_1 = R_{1a} = R_{1b} = 15 \text{ k}\Omega$, $R_2 = R_{2a} = R_{2b} = 13 \text{ k}\Omega$ and $R_3 = R_{3a} = R_{3b} = 89 \text{ k}\Omega$.

$$A_v = \boxed{}$$

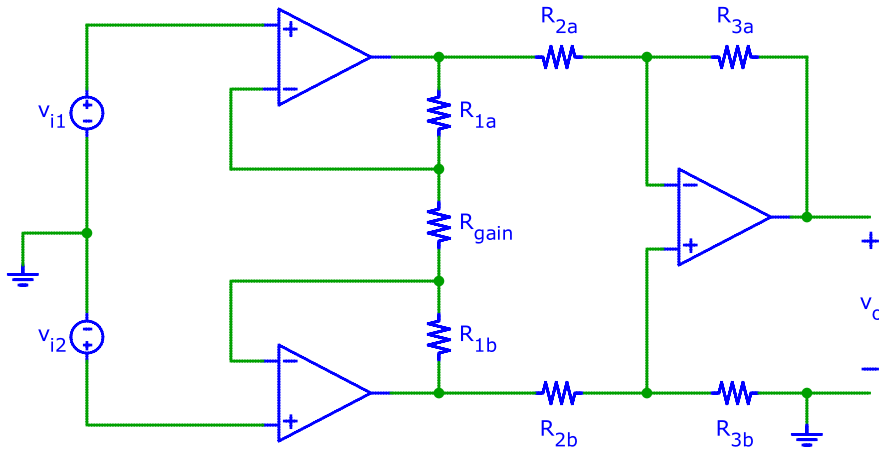

14. (D-41) (D-41) A 591 mF capacitor is used to power a model airplane. Initially the capacitor is charged to $V_o = 5\text{ V}$. Calculate the fraction r of the initial energy remaining on the capacitor after V_o has decreased to 75% of its initial value.

$r =$

15. (D-42) A parallel plate capacitor is used to measure the fluid level in a tank. It consists of two plates mounted vertically in the fluid tank and separated by a gap $g = 2.2\text{ mm}$. The width and height of the plates are $W = 23\text{ mm}$ and $H = 220\text{ mm}$, respectively. The relative permittivity of the fluid is $\epsilon_r = 62$ ($\epsilon_r = 1$ without fluid). Calculate the capacitance for the following conditions:

- Tank empty
- Tank 35% full
- Tank 71% full

16. (D-54) The digital CMOS circuits used in present computer chips communicate with binary signals with values 0 V and V_{dd} . The maximum operating speed is limited by how fast signals transition between these values.

The circuit below shows a typical situation of two digital circuits X_1 and X_2 connected by a wire. The capacitor C_1 is a model for the wire capacitance and the input capacitance of X_2 . Resistance R_o models the finite output resistance of X_1 . It is in reality part of X_1 but shown here separately to calculate the communication delay.

If v_1 transitions abruptly from 0 V to V_{dd} this change propagates to v_2 only gradually because of R_o and C_1 , limiting the maximum operation speed. Faster operation requires reducing R_o (or C_1). Since doing so increases the power dissipation of X_1 , it is important to determine the maximum allowable value $R_{o,max}$ that still ensures proper operation.

Find the $R_{o,max}$ that results in v_2 reaching 90% of its final value within 46 ps with $C_1 = 256\text{ fF}$ (typical numbers for microcomputer CPUs).

$R_{o,max} =$

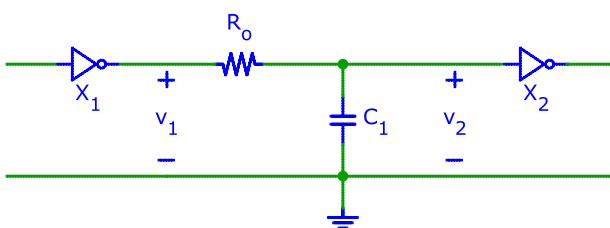

17. (D-57) Calculate the inductance between nodes (a,b) for $L_1 = 9.0 \mu\text{H}$, $L_2 = 7.5 \mu\text{H}$, $L_3 = 8.0 \mu\text{H}$, $L_4 = 3.6 \mu\text{H}$.

$L_{ab} =$

