

Due in the "EE 105 box" near 125 Cory Hall by 5pm on Monday 10/15/2012.

Read Chapter 6 in B. Razavi: Fundamentals of Microelectronics

Use the following parameters in all problems, unless otherwise specified:

$$\mu_n C_{ox} = 200 \mu\text{A}/\text{V}^2, \mu_p C_{ox} = 100 \mu\text{A}/\text{V}^2, V_{TH_n} = -V_{TH_p} = 400 \text{mV}, \gamma_n = \gamma_p = 0 \text{ (no body effect)}.$$

1. Answer the Exercise after Example 6.2 in B. Razavi: Fundamentals of Microelectronics.
2. Answer the Exercise after Example 6.5 in B. Razavi: Fundamentals of Microelectronics.
3. Answer the Exercise after Example 6.7 in B. Razavi: Fundamentals of Microelectronics.
4. Answer the Exercise after Example 6.8 in B. Razavi: Fundamentals of Microelectronics.
5. Answer the Exercise after Example 6.10 in B. Razavi: Fundamentals of Microelectronics.
6. Answer the Exercise after Example 6.11 in B. Razavi: Fundamentals of Microelectronics.
7. Answer the Exercise after Example 6.14 in B. Razavi: Fundamentals of Microelectronics.
8. The circuit below shows using a MOSFET as a switch. Varying  $V_G$  modulates the resistance  $R_{sd}$  between the source and drain of  $M_1$ . Determine the minimum value of  $W$  for which  $R_{sd} \leq 1 \text{ k}\Omega$  with  $V_1 = 0 \dots 2 \text{V}$ ,  $V_G = 3 \text{V}$  and  $I_D = 0$ . Note that for  $V_G = 0 \text{V}$  the value of  $R_{sd} \rightarrow \infty$ .

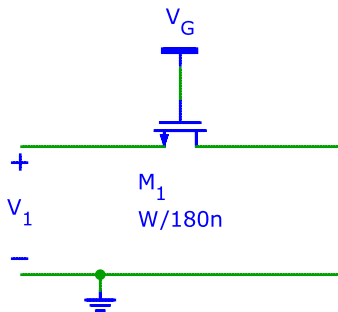

9. A pair of MOSFETs are used as a switch as shown below. Plot (remember how from an earlier assignment)  $R_{sd}$  for  $M_1$  and  $M_2$  individually and the combination of both devices (use the same axes) as a function of  $V_1 = 0 \dots V_G$  for  $V_G = 0.6 \text{ V}$ . Repeat with  $V_G = 1.8 \text{ V}$ . Assume  $R_{sd} \rightarrow \infty$  for  $|V_{GS}| < |V_{TH}|$ .

The CMOS switch (consisting of NMOS and PMOS transistors in parallel) operates at lower supply voltages than a single switch. For low supplies (e.g.  $V_G = 0.6 \text{ V}$ ) it is difficult or impossible ( $V_G < V_{TH}$ ) to turn on the switch. Good to know when a design calls for switches.

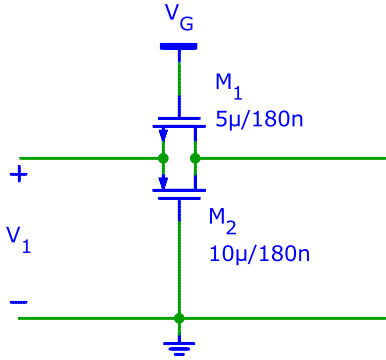

10. Problem 6.13 in B. Razavi: Fundamentals of Microelectronics.
11. Problem 6.18 in B. Razavi: Fundamentals of Microelectronics.
12. Problem 6.21 in B. Razavi: Fundamentals of Microelectronics.
13. The ratio of transconductance to bias current  $g_m/I_D$  is an important “figure of merit” of transistors: higher is better (more  $g_m$  for given current and power dissipation).
- Determine the value of  $g_m/I_C$  for a BJT at room temperature.
  - Determine the value of  $g_m/I_D$  for a MOSFET as a function of  $V_{GS} - V_{TH}$ .
  - Plot (you know how!)  $g_m/I_D$  as a function of  $V_{GS} - V_{TH} = 10 \dots 200 \text{ mV}$  and (in the same plot)  $g_m/I_C$  as a function of  $V_{BE}$ .
  - Apparently for small  $V_{GS} - V_{TH}$  the MOSFET has higher  $g_m/I_D$  than the BJT. That’s not actually the case: in reality, the “square law” equation applies only for MOSFETs in “strong inversion” when  $V_{GS} - V_{TH}$  is larger than about 200 mV. For small  $V_{GS} - V_{TH}$ , the MOSFET is in “weak inversion” and the relationship for  $I_D$  (in saturation) changes to

$$I_D = I_s e^{V_{GS}/nV_t}$$

In this expression,  $V_t$  is the thermal voltage and  $n$  is a device dependent parameter, typically  $n = 1.2 \dots 1.5$ . Calculate  $g_m/I_D$  for a MOSFET in weak inversion with  $n = 1.2$ . Add this trace to your plot (same axes). The actual  $g_m/I_D$  is the lower of the values predicted by the formula for weak and strong inversion.

In conclusion, MOSFETs have lower  $g_m/I_D$ , i.e. are less current efficient than BJTs. In some circuits—e.g. RF power amplifiers—this translates into lower power dissipation. But this is not the case for all circuit applications. For example, microprocessors built from MOS transistors dissipate usually less power than similar computers built from BJTs since more power efficient digital circuit topologies can be built from MOS transistors. It’s important to understand the differences between MOS and BJTs and use the best one depending on the application.

14. Determine the bias currents  $I_1$  and  $I_2$  for the followers below such that the small signal gains  $v_{oq}/v_{iq} \geq 0.99$  and  $v_{om}/v_{im} \geq 0.99$  for  $V_{oq} = V_{om} = 0$  V. Choose  $W$  such that  $V_{GS} - V_{TH} = 100$  mV.
- Which amplifier—MOS or BJT—has lower power dissipation?
  - Calculate the small-signal input resistance for both amplifiers. Which one is preferable based on input resistance?

